

AquaGo 1004 BF16

SURFACE MOUNT SENSOR OPERATED
NON-REFRIGERATED BOTTLE FILLER

STANDARD FEATURES

- Universal Mounting Points for Easy Retrofit Capability
- Fold Down Housing for Easy Maintenance Access
- Lead-Free
- 230-240 VAC/9 VDC plug-in Transformer
- 20-Second Maximum Run Time
- Laminar Flow Water Supply
- 1.0 GPM Fill Rate
- 100-Mesh Inlet Strainer
- ADA Compliant when installed correctly. Refer to 2010 ADA Standards for Accessible Design for complete Installation Requirements particularly if located on an Accessible Route or Circulation Path. Compliance is subject to the Interpretation and Requirements of the Local Code Authority

SUGGESTED SPECIFICATIONS

Model BF16 is a Surface Mount Sensor Operated Bottle Filler. Bottle Filling unit shall include Sensor Operated activation with a 20-second maximum run time. Housing has a slim and trim look that blends into your environment. Designed for Maintenance Advantage installation and service. Bottle Filler shall provide approximately 1.0 GPM flow rate with a Laminar Flow Spout to minimize splashing. When installed properly, the Bottle Filler complies with ADA forward and side reach requirements. Bottle Filler is fabricated of type 304 stainless steel polished to a satin finish with antimicrobial impact resistant ABS surfaces. Optional -BCD (Bottle Counter Display) indicates the quantity of 16 oz disposable Plastic Bottles saved from a land fill. -BCD option displays the Water Filter Status and includes LED Light to illuminate and brighten the Bottle Fill area when a Bottle is detected. Optional Water Filter meets NSF 42 and 53 requirements and reduces lead content in the drinking water by 99%. Unit shall be certified to Public Law 111-380 (NO-LEAD) and NSF/ANSI/CAN 61. Fixture meets ADA, ADA Standing Person, and ADA Child requirements when mounted appropriately.



Model BF16-BCD Shown
PATENT# D876,890 S

"INDOOR USE ONLY"

MODEL:

(Must Specify)

AquaGo 1004 BF16 AquaGo Murdock Surface Mounted Sensor Operated Bottle Filler with BCD Bottle Counter Display, 40mm Waste, supplied with 230-240VAC/9VDC Transformer Power Adaptor

WATERMARK APPROVED

Internal WATER FILTER, NOT SUPPLIED



Complies with the following standards:



Federal Public Law 111-380 (No Lead)



NSF/ANSI/CAN 61

⚠ WARNING: Cancer and Reproductive Harm - www.P65Warnings.ca.gov

MURDOCK MFG. • 15125 Proctor Avenue • City of Industry, CA 91746 USA
Phone 800-453-7465 or 626-333-2543 • www.murdockmfg.com

Member of
MORRIS GROUP
INTERNATIONAL

AquaGo 1004 BF16 www.shop.aquago.com.au

Revised: 01/11/2024

BF16 Series

SURFACE MOUNTED SENSOR OPERATED
NON-REFRIGERATED BOTTLE FILLER

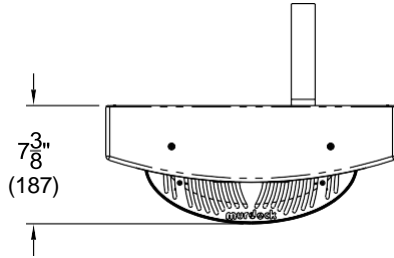

TOP VIEW

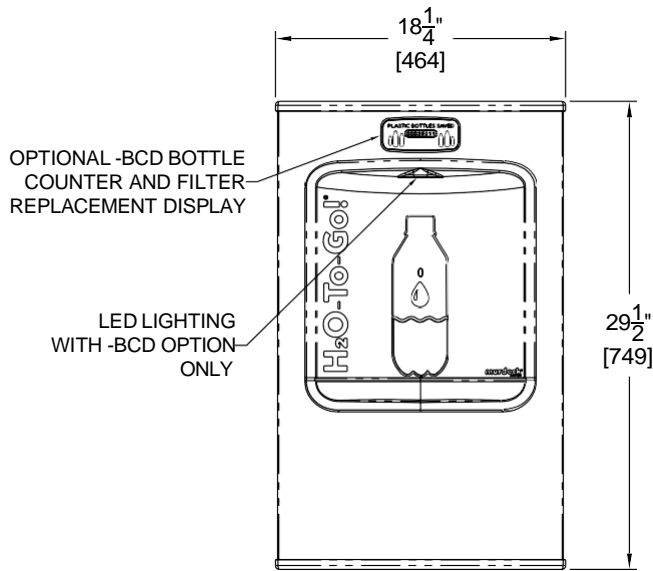

FRONT VIEW

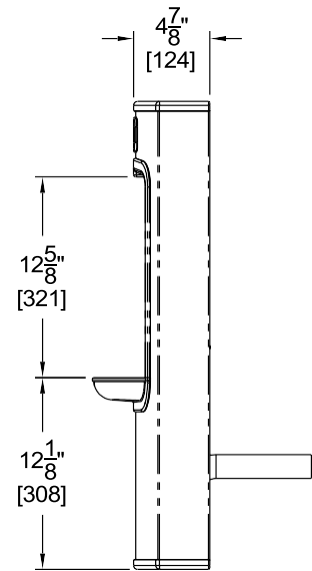

SIDE VIEW

GENERAL NOTES:
1. ALL DIMENSIONS ARE IN INCHES (MM)

SELECTION SUMMARY MANUFACTURING	Model Number & Options _____	Quantity _____	<i>All dimensions are subject to manufactures tolerance of plus or minus 1/4" nominal and subject to change without notice. Murdock[®] assumes no responsibility for use of void or superseded data. Dimensions may change with the addition of optional accessories. Murdock[®] Mfg., Member of Morris Group International[®]. Please visit www.murdockmfg.com for most current specifications.</i>
	Company _____		
	Contact _____	Title _____	
	Signature (Approval for Manufacturing) _____	Date _____	